 <p><b>VPAM</b> Association of test laboratories for bullet resistant materials and constructions</p>	<p>Test Standard</p> <p><b>“Stab and Impact Resistance”</b> <b>- Requirements, classifications and test procedures -</b></p>	<p><i>VPAM</i> <i>KDIW 2004</i> <b>Edition: 18.05.2011</b></p>
--	--	--

Test Standard

“Stab and Impact Resistance“

**Englische Übersetzung, es gilt immer die deutsche Originalfassung!**  
**English translation, however the original German version always prevails!**

Editor:

Vereinigung der Prüfstellen für angriffshemmende Materialien und  
Konstruktionen (VPAM)

As of: 18 MAY 2011

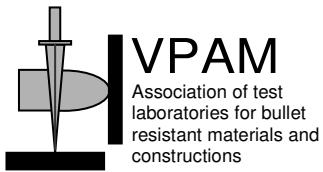
	<b>Test Standard</b> <b>“Stab and Impact Resistance”</b> <b>- Requirements, classifications and test procedures -</b>	<b>VPAM</b> <b>KDIW 2004</b> <b>Edition: 18.05.2011</b>
---	---	---

**First publication of VPAM KDIW 2004: 19 OCT 2005**

**List of Changes**

#	Change Date	Changes were made under the following numbers
1	13.10.2006	Preface, no 5.1 and 6.1
2	20.12.2006	No 3.6, 10.2, 10.13, 10.14 and Annex 1
3	08.05.2008	Preface, Annex 1 and Annex 6
4	15.10.2009	Preface, no 5 (table), 5.1 (manufacturer), 6 (table), 6.1 (drawing, manufacturer), 9.3, 9.4 and 10.9 (upper body protection for females)
5	12.05.2010	No 6.1 (drawing) and 8 (table)
6	18.05.2011	No 1, 3.2, 3.6, 3.12, 3.22, 3.23, 3.24, 3.25, 5 (table), 5.1, 6 (table), 6.1, 8 (table), 9.3 (footnote), 9.4 (footnote), 10.2, 10.5, 10.6, 10.9, 10.12, 10.13, 11.2, 11.3, Annexes 1 (drawing), 5 and 6

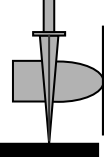
 <p><b>VPAM</b> Association of test laboratories for bullet resistant materials and constructions</p>	<p>Test Standard</p> <p><b>“Stab and Impact Resistance”</b> <b>- Requirements, classifications and test procedures -</b></p>	<p><i>VPAM</i> <i>KDIW 2004</i> <b>Edition: 18.05.2011</b></p>
--	--	--

## Preface

This test standard was produced by the Vereinigung der Prüfstellen für angriffshemmende Materialien und Konstruktionen (VPAM)

**VPAM KDIW 2004 is provided by:**

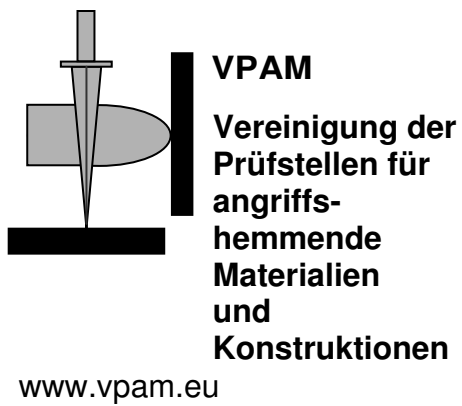

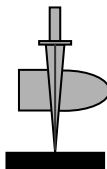
 <p><b>VPAM</b> Association of test laboratories for bullet resistant materials and constructions</p>	<p>Test Standard</p> <p><b>“Stab and Impact Resistance”</b> <b>- Requirements, classifications and test procedures -</b></p>	<p><i>VPAM</i> <i>KDIW 2004</i> Edition: 18.05.2011</p>
--	--	---

**Overview of requirements (test tools):**

Section

➤ **Stab resistance:**

- **Knife (blade)**

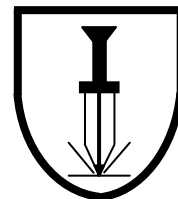

5

- **Nail (spike)**

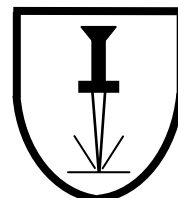

6

- **Needle (injection cannula)**

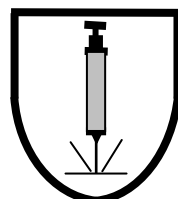

7

➤ **Impact resistance:**

- **Throwing and/or striking object with edges (block)**

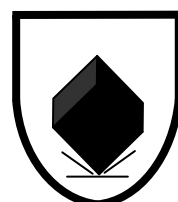

8

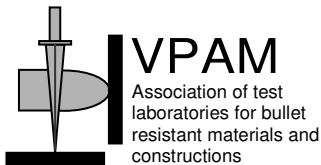
	<p>Test Standard</p> <p><b>“Stab and Impact Resistance”</b> - Requirements, classifications and test procedures -</p>	<p><i>VPAM</i> <b>KDIW 2004</b> Edition: 18.05.2011</p>
---	---	---

## Table of Contents

<b>1</b>	<b>Scope .....</b>	<b>7</b>
<b>2</b>	<b>Normative and Other References .....</b>	<b>8</b>
<b>3</b>	<b>Terms and Definitions .....</b>	<b>9</b>
<b>3.1</b>	<b>Protective Equipment .....</b>	<b>9</b>
<b>3.2</b>	<b>Protection Area .....</b>	<b>9</b>
<b>3.3</b>	<b>Protection Class.....</b>	<b>9</b>
<b>3.4</b>	<b>Stab-Resistant Armour .....</b>	<b>9</b>
<b>3.5</b>	<b>Impact-Resistant Armour .....</b>	<b>9</b>
<b>3.6</b>	<b>Test Specimen.....</b>	<b>10</b>
<b>3.7</b>	<b>Sample .....</b>	<b>10</b>
<b>3.8</b>	<b>Stab Resistance .....</b>	<b>10</b>
<b>3.9</b>	<b>Impact Resistance.....</b>	<b>10</b>
<b>3.10</b>	<b>Backing Material .....</b>	<b>10</b>
<b>3.11</b>	<b>Deformation depth .....</b>	<b>10</b>
<b>3.12</b>	<b>Puncture Depth .....</b>	<b>10</b>
<b>3.13</b>	<b>Strike Face.....</b>	<b>10</b>
<b>3.14</b>	<b>Stab Penetration .....</b>	<b>11</b>
<b>3.15</b>	<b>Impact Point .....</b>	<b>11</b>
<b>3.16</b>	<b>Distance between strikes .....</b>	<b>11</b>
<b>3.17</b>	<b>Strike-to-Edge Distance.....</b>	<b>11</b>
<b>3.18</b>	<b>Drop Height .....</b>	<b>11</b>
<b>3.19</b>	<b>Angle of Incidence .....</b>	<b>11</b>
<b>3.20</b>	<b>Test Tool.....</b>	<b>11</b>
<b>3.21</b>	<b>Drop Mass.....</b>	<b>11</b>
<b>3.22</b>	<b>Juncture.....</b>	<b>11</b>
<b>3.23</b>	<b>Overlap.....</b>	<b>12</b>
<b>3.24</b>	<b>Inhomogeneous Protective Materials.....</b>	<b>12</b>
<b>3.25</b>	<b>Model Name or Model Code .....</b>	<b>12</b>
<b>4</b>	<b>Requirements and Classifications.....</b>	<b>13</b>
<b>4.1</b>	<b>Requirements .....</b>	<b>13</b>
<b>4.2</b>	<b>Classification.....</b>	<b>13</b>
<b>5</b>	<b>Testing of Stab Resistance against Knife (Blade).....</b>	<b>14</b>
<b>5.1</b>	<b>Test Tool Blade .....</b>	<b>15</b>
<b>6</b>	<b>Testing of Stab Resistance against Nail (Spike) .....</b>	<b>16</b>
<b>6.1</b>	<b>Test Tool Nail (Spike).....</b>	<b>17</b>
<b>7</b>	<b>Testing of Stab Resistance against Needle (Injection Cannula).....</b>	<b>18</b>
<b>7.1</b>	<b>Test Tool Injection Cannula .....</b>	<b>18</b>
<b>8</b>	<b>Testing of Impact Resistance against Throwing and/or Striking Object with Edges (Block).....</b>	<b>19</b>
<b>8.1</b>	<b>Test Tool Block (Edge of a Block) .....</b>	<b>20</b>
<b>9</b>	<b>Test Set-up and Test Equipment .....</b>	<b>21</b>
<b>9.1</b>	<b>Drop Test Apparatus.....</b>	<b>21</b>
<b>9.4</b>	<b>Testing of Plasticity .....</b>	<b>21</b>

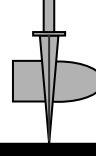
 <p><b>VPAM</b> Association of test laboratories for bullet resistant materials and constructions</p>	<p>Test Standard</p> <p><b>“Stab and Impact Resistance”</b> - Requirements, classifications and test procedures -</p>	<p><i>VPAM</i> <i>KDIW 2004</i></p> <p><b>Edition: 18.05.2011</b></p>
--	---	---

<b>9.5</b>	<b>Selection of Test Tools.....</b>	<b>22</b>
<b>10</b>	<b>Test Procedure.....</b>	<b>23</b>
<b>10.1</b>	<b>Number of Test Specimens.....</b>	<b>23</b>
<b>10.2</b>	<b>Size of Test Specimens.....</b>	<b>23</b>
<b>10.3</b>	<b>Conditioning of Test Specimens.....</b>	<b>23</b>
<b>10.4</b>	<b>Testing of Backing Materials.....</b>	<b>23</b>
<b>10.5</b>	<b>Affixing of Test Specimens.....</b>	<b>23</b>
<b>10.6</b>	<b>Identification of Impact Points.....</b>	<b>23</b>
<b>10.7</b>	<b>Positioning of the Test Specimen.....</b>	<b>24</b>
<b>10.8</b>	<b>Angle of Incidence.....</b>	<b>24</b>
<b>10.9</b>	<b>Number and Distance of Strikes.....</b>	<b>24</b>
<b>10.10</b>	<b>Accuracy of Strikes.....</b>	<b>25</b>
<b>10.11</b>	<b>Ambient Temperature.....</b>	<b>25</b>
<b>10.12</b>	<b>Conduct of Testing.....</b>	<b>25</b>
<b>10.13</b>	<b>Determination of the Test Results.....</b>	<b>26</b>
<b>10.14</b>	<b>Repetition Testing.....</b>	<b>26</b>
<b>11</b>	<b>Evaluation and Documentation of the Test, Test Certificate.....</b>	<b>27</b>
<b>11.1</b>	<b>Evaluation of the Test.....</b>	<b>27</b>
<b>11.2</b>	<b>Test Report.....</b>	<b>27</b>
<b>11.3</b>	<b>Test Certificate/Verification Certificate.....</b>	<b>28</b>
<b>11.4</b>	<b>Validity of the Test Certificate/Verification Certificate.....</b>	<b>29</b>
<b>11.5</b>	<b>Reproducibility of the results.....</b>	<b>29</b>
<b>11.6</b>	<b>Specifications of the Materials/Material Processing.....</b>	<b>29</b>
	<b>Annex 1: Measuring and Targeting Set-up.....</b>	<b>30</b>
	<b>Annex 2: Presentation of the Stab Impact Locations.....</b>	<b>31</b>
	<b>Annex 3: Presentation of the Stab Imp. Locations in the Event of Junctures ..</b>	<b>32</b>
	<b>Annex 4: Presentation of the Stab Impact Locations in the Event of Overlaps</b>	<b>33</b>
	<b>Annex 5: Testing of Protective Helmets.....</b>	<b>34</b>

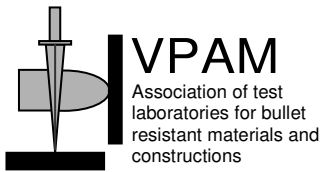
	<p>Test Standard</p> <p><b>“Stab and Impact Resistance”</b>  <b>- Requirements, classifications and test procedures -</b></p>	<p><i>VPAM</i>  <b>KDIW 2004</b>  <b>Edition: 18.05.2011</b></p>
---	---	--

## 1 Scope

The test standard “Stab and Impact Resistance“ describes the requirements, classifications and test procedures for stab and impact resistant protective equipment, such as **body armour**, **protective helmets** and **protective shields**. These are items designed to protect against injury caused by attacks with stab and impacting objects.

The standard ensures reproducible results, and provides customers and users with a better market transparency. Therefore it becomes possible to objectively compare the products of various providers, which have been tested in accordance with this standard.

Additional requirements may be included. The **body armour** may be configured as follows:

- **Combined Protection (“In Conjunction Armour”)**  
 If an already tested stab and/or impact-resistant armour is to be worn in conjunction with an already tested ballistic armour, the combination shall also be submitted to a ballistic test (3 shots at an angle of 90°, or in the event of an overlapping model 3 shots at 25°, without prior conditioning).
- **Upgradable Protection (“In Conjunction Armour”)**  
 If an already tested ballistic armour is to be upgraded with stab and/or impact resistance, the combination shall be submitted to a complete stab and/or impact test as well as the ballistic test (3 shots at an angle of 90°, in the event of an overlapping model 3 shots at 25°, without prior conditioning).
- **Integrated Protection**  
 If body armour is designed to provide both ballistic protection and stab and/or impact resistance, the non-separable armour panel is to be subjected to both a ballistic test and a stab and/or impact resistance test.

Should, during the course of a test, a weak area be identified which is not covered by the tests of this standard or the ballistic standard, the examiner shall proceed testing as per this standard.

This standard requires specimens of size “S” to be tested. Should the requester/procurer submit other sizes in addition, then they shall determine the extent of possible further tests required.

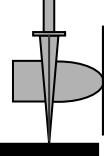
 <p><b>VPAM</b> Association of test laboratories for bullet resistant materials and constructions</p>	<p>Test Standard</p> <p><b>“Stab and Impact Resistance”</b> <b>- Requirements, classifications and test procedures -</b></p>	<p><i>VPAM</i> <i>KDIW 2004</i> <b>Edition: 18.05.2011</b></p>
--	--	--

## 2 Normative and Other References

The following normative/other documents include definitions which, by way of reference in this text, are an element of this standard. Dated references do not take into consideration earlier changes or revisions of this publication.

Contract parties applying this standard are recommended to check the availability of more recent editions of the normative documents given below.

In the event of undated references, the latest edition of the normative document referred to is to be used. Legal provisions are always to be used as amended.

- **DIN EN 10204**, Metallische Erzeugnisse - Arten von Prüfbescheinigungen [Metallic Manufacture – Types of Verification Certificates]
- **DIN EN 13087-3**, Schutzhelme - Prüfverfahren - Teil 3 [Protective Helmets – Testing Regulations – Part 3]: Penetration Resistance
- **DIN EN ISO 7864**, Sterile Einmal-Injektionskanülen [Sterile Single-Use Injection Cannula]
- **ECE R 22**, uniform provisions concerning the approval of protective helmets (crash helmets) for drivers and passengers (sidecar passengers) of motor cycles, bicycles with auxiliary motor, and mopeds
- **VPAM - BSW 2006** Testing Guideline “Ballistic Protective Vests”

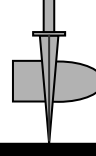

 <p><b>VPAM</b> Association of test laboratories for bullet resistant materials and constructions</p>	<p>Test Standard</p> <p><b>“Stab and Impact Resistance”</b> <b>- Requirements, classifications and test procedures -</b></p>	<p><i>VPAM</i> <i>KDIW 2004</i></p> <p><b>Edition: 18.05.2011</b></p>
--	--	---

### **3 Terms and Definitions**

The following definitions are effective for the purpose of this test standard:

#### **3.1 Protective Equipment**

Garments such as upper body, arm, leg, lower abdomen protectors, protective helmets and protective shields. These items are designed to protect against injury resulting from attacks.

#### **3.2 Protection Area**

Area which is covered by the protective equipment in the category to be tested. When issuing a request for testing, the requester/manufacturer is to indicate the protection area to be tested.

#### **3.3 Protection Class**

Designation of the classification of the intended protection level, against a specific attack potential.

#### **3.4 Stab-Resistant Armour**

In general a product consisting of a weave, mesh, plates, etc. in a single-layered or two-layered stab-resistant armour panel. The panel has a consistently uniform cross-section.

#### **3.5 Impact-Resistant Armour**

In general a product consisting of a weave, mesh, plates, etc. in a single-layered or multilayered impact-resistant armour panel. The panel has a consistently uniform cross-section.

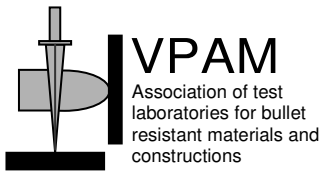
	<p>Test Standard</p> <p><b>“Stab and Impact Resistance”</b>  <b>- Requirements, classifications and test procedures -</b></p>	<p><i>VPAM</i>  <b>KDIW 2004</b>  <b>Edition: 18.05.2011</b></p>
---	---	--

### 3.6 Test Specimen

A size “S” specimen which is prepared for testing. Within the framework of procurement, the requester/procurer may additionally submit other sizes.

Note: The structure and the materials of the specimen shall comply with the manufacturer’s description, or the requirements of the requester and shall meet the customary quality of the product(s). The test specimen must be accompanied by acceptance test certificates (e.g. batch number) and documentation, which specify the exact composition, especially materials used, and production and processing procedures.

### 3.7 Sample

Several test specimens required for testing in accordance with this test standard.

### 3.8 Stab Resistance

Resistance with which a stab-resistant armour panel opposes the penetration of a defined stabbing tool.

### 3.9 Impact Resistance

Resistance with which an impact-resistant armour panel opposes the effect of a defined blunt impact tool.

### 3.10 Backing Material

For testing, the backing material is placed behind a test specimen, reliably indicating the depth of the deformation and the penetration of the rear surface of the test specimen by a stabbing tool, or the depth of the deformation caused to the test specimen’s rear surface in the event of an impact test.

### 3.11 Deformation depth

Degree of deformation with regard to the original surface of the backing material.

### 3.12 Puncture Depth

The depth of penetration caused by the point of a test tool, through the rear of the test specimen into the backing material (see Annex 1).

### 3.13 Strike Face

The surface of a test specimen designated, by the manufacturer or requester, as the surface which should face the incoming threat.

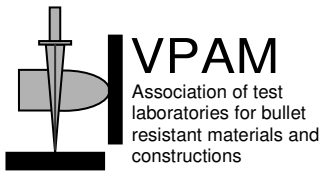
	<p>Test Standard</p> <p><b>“Stab and Impact Resistance”</b>  <b>- Requirements, classifications and test procedures -</b></p>	<p><i>VPAM</i>  <b>KDIW 2004</b>  <b>Edition: 18.05.2011</b></p>
---	---	--

### **3.14 Stab Penetration**

Condition, in which the rear surface of the test specimen has been penetrated by the stabbing tool.

### **3.15 Impact Point**

The location on the test specimen where the test tool is intended to strike.

### **3.16 Distance between strikes**

The distance from the centres of two strikes on the test specimen.

### **3.17 Strike-to-Edge Distance**

The distance from an impact point to the nearest line that designates the edge of the protection area.

### **3.18 Drop Height**

The distance between the point of the test tool and the front surface of the test specimen (strike face).

### **3.19 Angle of Incidence**

The angle between the direction of the test tool and a line that is perpendicular (90°, corresponds to 0° NATO) to the strike face of the test specimen.

### **3.20 Test Tool**

Threat weapons, such as blade, spike, injection cannula or block, for the testing of stab resistance and/or impact resistance.

### **3.21 Drop Mass**

The fixture including the test tool.

### **3.22 Juncture**

The area where protective materials butt up against each other. Connecting components shall not be viewed as an overlap. Lateral connection points going from the front to the rear shall not be viewed as junctures.

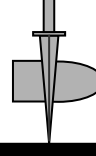
 <p><b>VPAM</b> Association of test laboratories for bullet resistant materials and constructions</p>	<p>Test Standard</p> <p><b>“Stab and Impact Resistance”</b> <b>- Requirements, classifications and</b> <b>test procedures -</b></p>	<p><i>VPAM</i> <i>KDIW 2004</i> <b>Edition: 18.05.2011</b></p>
--	---	--

### **3.23 Overlap**

The area in which the full thickness of the protective materials overlap completely . Lateral connection points going from the front to the rear shall not be viewed as overlap sections.

### **3.24 Inhomogeneous Protective Materials**

Materials with a clearly distinguishable, unequal mass distribution or other characteristics. These materials, such as ring mesh, wire weave, perforated metal plate or ceramic tiles may lead to an increased penetration probability.

### **3.25 Model Name or Model Code**

The name or code designating a set of protective equipment. All protective equipment of a specific model shall be identical in its structure, protection class and minimum protection area. A model may be available in various sizes.

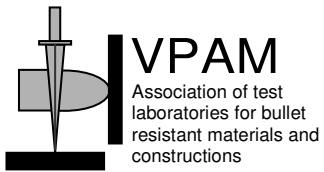
	<p>Test Standard</p> <p><b>“Stab and Impact Resistance”</b>  <b>- Requirements, classifications and test procedures -</b></p>	<p><i>VPAM</i>  <i>KDIW 2004</i>  <b>Edition: 18.05.2011</b></p>
---	---	--

## 4 Requirements and Classifications

### 4.1 Requirements

#### ➤ Stab Resistance

- Knife (blade)
- Nail (spike)
- Needle (injection cannula)

#### ➤ Impact Resistance

- Throwing and/or striking object with edges (block)

### 4.2 Classification

Test specimens withstanding the exposure to specific attack forms are classified in accordance within Tables 1, 2, 3 or 4 (sections 5 to 8) or any combination thereof.

An example of the classification designation is:

***K1/D2/I1/W3 as per VPAM - KDIW 2004***

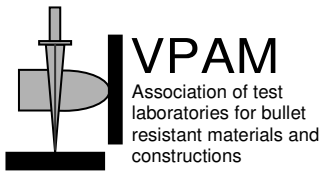
	<b>Test Standard</b> <b>“Stab and Impact Resistance”</b> <b>- Requirements, classifications and test procedures -</b>	<b>VPAM</b> <b>KDIW 2004</b> <b>Edition: 18.05.2011</b>
---	---	---

## 5 Testing of Stab Resistance against Knife (Blade)

Table 1: Classification and Test Conditions

<b>Class (blade)</b>	<b>Impact point</b>	<b>Strike energy [J]</b>	<b>Angle of incidence [degrees]</b>	<b>Greatest single stab penetration depth [mm]</b>
<b>K 1</b>	area	25	90	< 20
	seam			
	overlap		25	
<b>K 2</b>	area	40	90	< 20
	seam			
	overlap		25	
<b>K 3</b>	area	65	90	< 20
	seam			
	overlap		25	
<b>K 4</b>	area	80	90	< 20
	seam			
	overlap		25	

The classes termed as K 1 to K 4 in Table 1 are arranged in ascending order according to their stab resistance. Class K 1 offers the least and Class K 4 the highest resistance against a knife (blade). When the stab-resistant material has fulfilled the criteria for a specific protection class, it is deemed to meet to the class or classes below it.

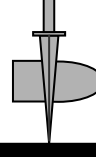
 <p><b>VPAM</b> Association of test laboratories for bullet resistant materials and constructions</p>	<p>Test Standard</p> <p><b>“Stab and Impact Resistance”</b> <b>- Requirements, classifications and test procedures -</b></p>	<p><b>VPAM</b> <b>KDIW 2004</b> <b>Edition: 18.05.2011</b></p>
--	--	--

## 5.1 Test Tool Blade

Drawing No 1: Blade

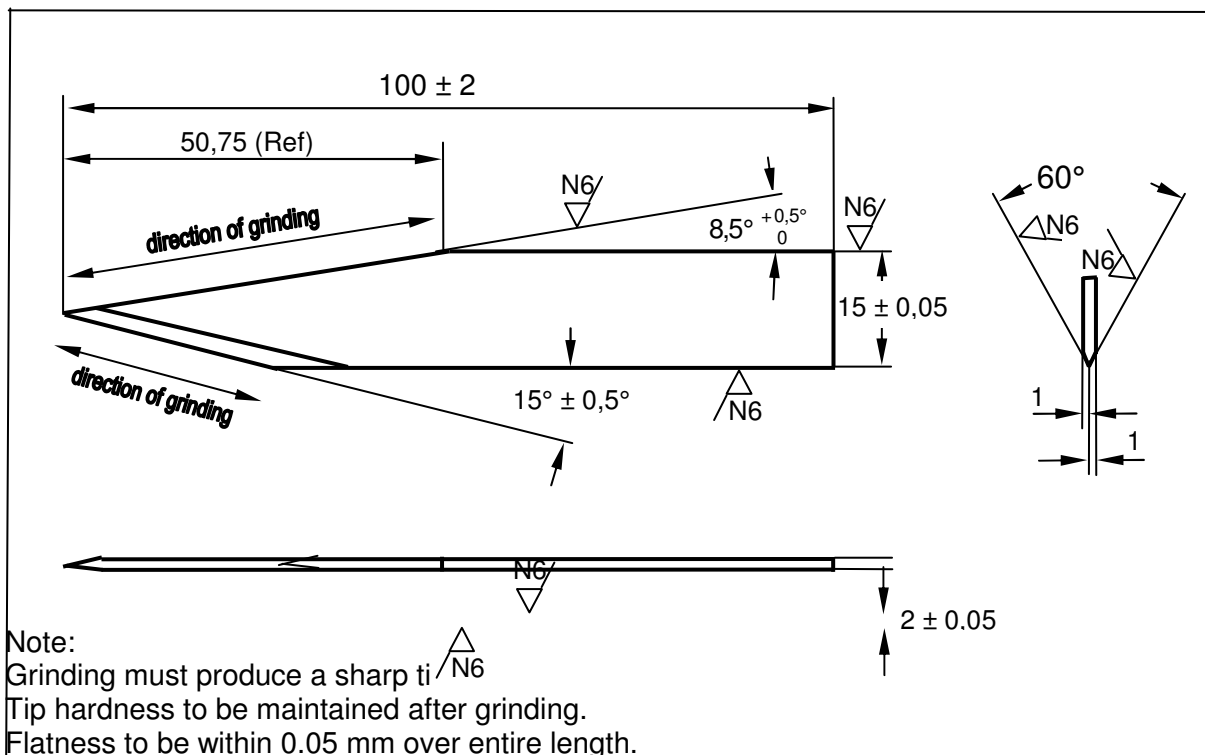

<b>Blade P1/B</b>	<b>Tolerances:</b> (unless otherwise stated) $\pm 0.25$ mm	<b>Material:</b> Cold-rolled steel, and hardened tempered 52-55 Rockwell C	<b>Scale:</b> not to scale dimensions in mm
-------------------	---	---	--

**Manufacturer:** Victorinox AG., 6438 Ibach - Schwyz, Switzerland

The smallest available packaging unit of the blades are to be delivered by the manufacturer with a manufacturer code and a production code.

Before testing, the blades are to be wiped clean of grease.

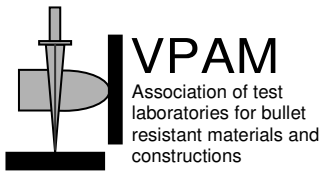
	<b>Test Standard</b> <b>“Stab and Impact Resistance”</b> <b>- Requirements, classifications and test procedures -</b>	<b>VPAM</b> <b>KDIW 2004</b> <b>Edition: 18.05.2011</b>
---	---	---

## 6 Testing of Stab Resistance against Nail (Spike)

Table 2: Classification and Test Conditions

Class (spike)	Impact point	Strike energy [J]	Angle of incidence [degrees]	Greatest single stab penetration depth [mm]
D 1	area	25	90	< 20
	seam		25	
	overlap			
D 2	area	40	90	< 20
	seam		25	
	overlap			
D 3	area	65	90	< 20
	seam		25	
	overlap			
D 4	area	80	90	< 20
	seam		25	
	overlap			

The classes termed as D 1 to D 4 in Table 2 are arranged in ascending order according to their stab resistance. Class D 1 offers the least and Class D 4 the highest resistance against a nail (spike). When the spike-resistant material has fulfilled the criteria for a specific protection class, it is deemed to meet to the class or classes below it.

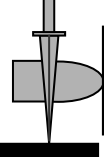

 <p><b>VPAM</b> Association of test laboratories for bullet resistant materials and constructions</p>	<p>Test Standard</p> <p><b>“Stab and Impact Resistance”</b> - Requirements, classifications and test procedures -</p>	<p><b>VPAM</b> <b>KDIW 2004</b> Edition: 18.05.2011</p>
--	---	---

## 6.1 Test Tool Nail (Spike)

Drawing No 2: Spike

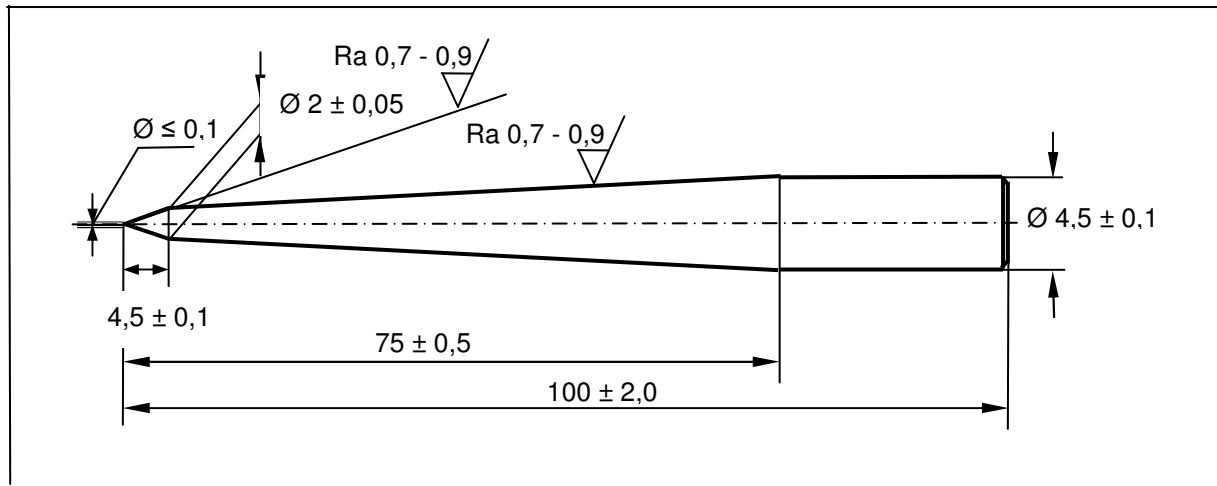

<p><b>Spike</b></p>	<p><b>Tolerances:</b> (unless otherwise stated) <math>\pm 0.25</math> mm</p>	<p><b>Material: Steel 100 Cr 6</b> <b>UN No: 1.2067</b> <b>Hardness: 445-510 HV10</b></p>	<p><b>Scale:</b> not to scale <b>Measurements:</b> in mm, Ra: in <math>\mu</math>m</p>
---------------------	--	---	--

**Manufacturer:** Jugard+Künstner GmbH, Thomas-Mann-Str. 63, D-90471 Nürnberg, Germany, (shipment includes spike with test certificate)

The smallest available packaging unit of the spikes are to be delivered by the manufacturer with a manufacturer code and a production code.

Before testing, the spikes are to be wiped clean of grease.

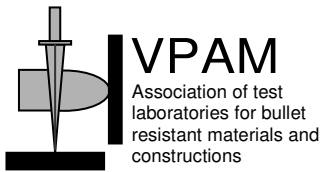
	<b>Test Standard</b> <b>“Stab and Impact Resistance”</b> <b>- Requirements, classifications and test procedures -</b>	<b>VPAM</b> <b>KDIW 2004</b> <b>Edition: 18.05.2011</b>
---	---	---

## 7 Testing of Stab Resistance against Needle (Injection Cannula)

Table 3: Classification and Test Conditions

Class (injection cannula)	Impact point	Strike energy [J]	Angle incidence [degrees]	of	Stab penetration [mm]
I 1	area	2,5	90	0	
	seam				60
	overlap				

Perforation by pushing-through the injection cannula is to be tested under the following conditions:

Angle: 90°

Force applied by injection cannula on test specimen increasing from 0 to 20 Newtons

Feed rate: 10 mm/min.

In so doing, the test specimen must not be punctured. The force when the needle breaks shall be documented, if applicable.

### 7.1 Test Tool Injection Cannula

The cannulas are to correspond in shape and measurements to DIN EN ISO 7864.

**Needle size:** 21G x 1 1/2", Diameter: 0.8 ± 0.01 mm,

**Length:** 40 ± 2 mm, No. 2

**Manufacturer:** Terumo Europe N.V. 3001 Leuven, Belgium, or an equivalent product from another manufacturer, when the proof can be given that tests will have the same result.

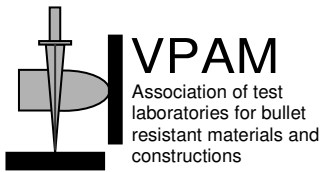
	<b>Test Standard</b> <b>“Stab and Impact Resistance”</b> <b>- Requirements, classifications and test procedures -</b>	<b>VPAM</b> <b>KDIW 2004</b> <b>Edition: 18.05.2011</b>
---	---	---

## 8 Testing of Impact Resistance against Throwing and/or Striking Object with Edges (Block)

Table 4: Classification and Test Conditions

Class (block)	Impact point	Strike energy [J]	Angle incidence [degrees]	of	Average deformation depth [mm]
W 1	area	15	90		< 20
	seam				
	overlap				
W 2	area	25	90		< 20
	seam				
	overlap				
W 3	area	40	90		< 20
	joint				
	overlap				
W 4	area	65	90		< 20
	seam				
	overlap				
W 5	area	100	90		< 20
	seam				
	overlap				

The classes termed as W 1 to W 5 in Table 4 are arranged in ascending order according to their impact resistance. Class W 1 offers the least, Class W 5 the highest resistance against a throwing or striking object with edges (block). When the impact-resistant material has fulfilled the criteria for a specific protection class, it is deemed to meet to the class or classes below it.

---

<sup>1</sup> Average of 3 drops.

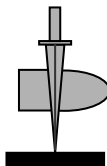
 <p><b>VPAM</b> Association of test laboratories for bullet resistant materials and constructions</p>	<p>Test Standard</p> <p><b>“Stab and Impact Resistance”</b> <b>- Requirements, classifications and test procedures -</b></p>	<p><i>VPAM</i> <i>KDIW 2004</i> Edition: 18.05.2011</p>
--	--	---

### 8.1 Test Tool Block (Edge of a Block)

Drawing No 3: Block (edge of a block)

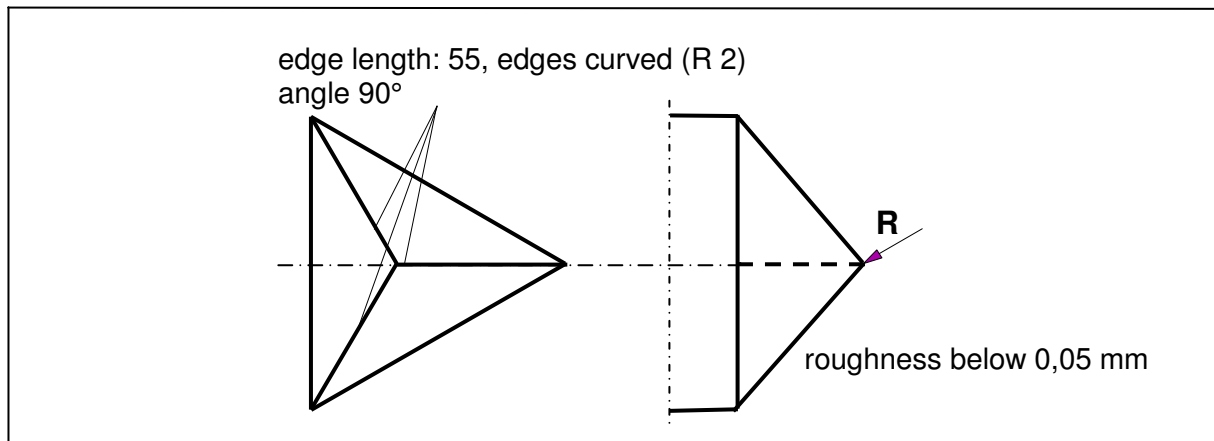

<p><b>Block</b></p>	<p><b>Tolerances:</b> (unless otherwise stated) <b>±0.25 mm</b></p>	<p><b>Material:</b> Steel, hardened and tempered <b>55 ± 5 Rockwell C</b></p>	<p><b>Scale:</b> not to scale dimensions in mm</p>
---------------------	---	---	--

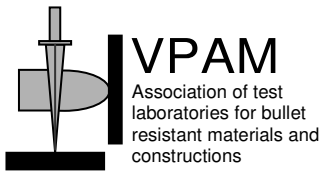
	<p>Test Standard</p> <p><b>“Stab and Impact Resistance”</b>  <b>- Requirements, classifications and test procedures -</b></p>	<p><i>VPAM</i>  <b>KDIW 2004</b>  <b>Edition: 18.05.2011</b></p>
---	---	--

## 9 Test Set-up and Test Equipment

### 9.1 Drop Test Apparatus

The stab and impact resistance tests shall be performed on test specimens using a drop test apparatus. The measuring and targeting set-up is described in Annex 1.

The apparatus shall ensure that the test tool impacts the test specimen vertically (angle of incidence 90°, 0° NATO) and continues in this direction. The drop test apparatus shall be designed in such a way that the individual strike energies are within 3 per cent of the strike energy levels listed within the respective tables, and that the average strike energy levels of 10 hits of a standard test series are within 1 per cent.

### 9.2 Push-Through Test Apparatus

The push-through test shall be made with an apparatus that is especially designed for this type of material testing.

### 9.3 Backing Material

In order to accommodate the test specimens and to determine the deformation and the penetration depth, plasticine shall be used.

<sup>2</sup> The plasticine shall fill a box of internal dimensions 350 mm x 400 mm x 150 mm.

<sup>3</sup> Prior to testing, the box shall be conditioned for a minimum of 16 hours at a constant temperature ( $\pm 2$  C). This ensures the plasticity of  $20.0 \pm 2.0$  mm. Before the plasticity measurement, the plasticine shall be subjected to approx. 30 hits (e.g. with a wooden hammer) and, subsequently, the plasticine shall be drawn off with a blade.

### 9.4 Testing of Plasticity

The box of plasticine shall be placed on a sufficiently stable footing. In order to test the plasticity of the plasticine a ball drop system with a steel ball (diameter  $63.5 \pm 0.05$  mm, mass  $1,039 \pm 5$  g) shall be used. <sup>4</sup> The distance between the lower edge of the ball and the surface of the plasticine shall be  $2,000 \pm 5$  mm. The planar surface of the plasticine shall be horizontal at the point of impact of the ball, with an accuracy of  $\pm 5$  mm at 1 m. The ball shall be dropped five times onto the plasticine. The centre of a point of impact shall be no closer than 80 mm from any edge of the box and no closer than 140 mm from the centre of another point of impact. The indentations (depressions) in the plasticine result in a “die-pentagon”. Before or after the ball has been dropped, the plasticine shall be drawn off and,

<sup>2</sup> Plasticine manufactured by Carl Weible KG, Postfach 1648, 73606 Schorndorf.

<sup>3</sup> Should a procurer request that test specimens of larger sizes than S be tested, the dimensions (length and width) of the box must be correspondingly larger.

<sup>4</sup> Similar products may be used if it has been demonstrated that they produce the same results.

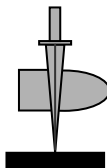
 <p><b>VPAM</b> Association of test laboratories for bullet resistant materials and constructions</p>	<p>Test Standard</p> <p><b>“Stab and Impact Resistance”</b> <b>- Requirements, classifications and test procedures -</b></p>	<p><i>VPAM</i> <i>KDIW 2004</i> <b>Edition: 18.05.2011</b></p>
--	--	--

subsequently, the indentation depth shall be measured. The resulting depressions shall not be filled in. The lowest point of the indentation of the ball in the plasticine, relative to the surface of the plasticine before the test, shall be measured with a measuring accuracy of  $\pm 0.5$  mm.

The plasticine with its associated conditioning temperature is acceptable when the depth of each depression is  $20 \pm 2$  mm.

The plasticine shall meet the requirements of the indentation geometry throughout the test period. Prior to sample testing, plasticity shall be measured and the average, calculated from the five measurements, shall be stated in the test report.

### **9.5 Selection of Test Tools**

The dimensions and designs of the test tools shall correspond to the requirements given in sections 5 through 8. The measurements, the hardness and the grinding direction of the test tools shall be verified.

For stab tests in accordance with sections 5 through 7, a new test tool shall be used for every single test strike, firmly clamped into the holding bracket.

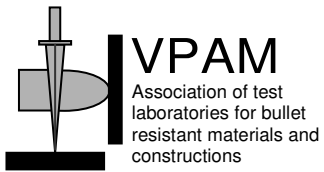
	<p>Test Standard</p> <p><b>“Stab and Impact Resistance”</b>  <b>- Requirements, classifications and test procedures -</b></p>	<p><i>VPAM</i>  <b>KDIW 2004</b>  <b>Edition: 18.05.2011</b></p>
---	---	--

## 10 Test Procedure

### 10.1 Number of Test Specimens

For each set of protective equipment to be tested, at least 4 (cf. section 10.9) identical test specimens (samples) shall be submitted at the same time. One test specimen shall be kept as a reserve. If diverse requirements are to be tested in combination, then the number of test specimens shall be increased accordingly. All test specimens shall be tested within a narrow timeframe.

### 10.2 Size of Test Specimens

Only size “S” protective equipment items shall be used for testing.

### 10.3 Conditioning of Test Specimens

Prior to testing, the test specimens shall be conditioned in equal numbers for at least for 12 hours at:

- $-20 \pm 2$  °C
- $+20 \pm 2$  °C and  $65 \pm 5$  per cent relative humidity
- $+70 \pm 2$  °C

### 10.4 Testing of Backing Materials

Before or after every test strike, the plasticity of the backing material shall be determined in accordance with section 9.4. The institute conducting the test shall ensure that the plasticity of the backing material is maintained within the permitted range throughout the test.

### 10.5 Affixing of Test Specimens

The specimen to be tested shall be placed on the plasticine block and shall be attached with two rubber straps in parallel with the upper and the lower edge. The specimen may be supported from below, if required.<sup>5</sup> Elasticity of the rubber straps shall be 10 - 20 Newtons. Pre-fabricated parts shall be backed with plasticine according to their shape. When testing at angles < 90°, the box of plasticine shall be positioned accordingly.

### 10.6 Identification of Impact Points

The impact points on the test specimen shall be marked and numbered as per Annexes 2, 3 or 4 of this standard.

Upon request from the requester, the distance from one strike to the next one and from the edge may be reduced.

Should, during the course of a test, a weak area, which is not covered by the test requirements of this test standard, be identified, it is up to the discretion of the institute

---

<sup>5</sup> Neoprene rubber: Hardness 40 - 60 IHRD, 4 mm thick, 40 mm wide, 750 mm long, punched (manufacturer: Semperit)

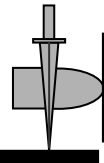
 <p><b>VPAM</b> Association of test laboratories for bullet resistant materials and constructions</p>	<p>Test Standard</p> <p><b>“Stab and Impact Resistance”</b> <b>- Requirements, classifications and test procedures -</b></p>	<p><i>VPAM</i> <b>KDIW 2004</b> <b>Edition: 18.05.2011</b></p>
--	--	--

conducting the test whether to proceed testing as per this standard. If required, further test specimens shall be used.

### 10.7 Positioning of the Test Specimen

For testing, the test specimen, which is affixed to the plasticine block, shall be positioned in such a way that the test tool hits the test specimen on the previously marked location.

### 10.8 Angle of Incidence

The test tool has to impact the test specimen at the angles given in the respective tables, with an accuracy of  $\pm 2^\circ$ .

### 10.9 Number and Distance of Strikes

Table 5: Number of Strikes per Test Tool

Impact point / angle of incidence		Test conditions		
		+20° C	+70° C	-20° C
Area / 90°	Test specimen no.	1	2	3
	Number of strikes/dispersi on pattern	3 / Annex 2	3 / Annex 2	3 / Annex 2
Seam / 90°	Test specimen No.	4	5	6
	Number of strikes/dispersi on pattern	3 / Annex 3	3 / Annex 3	3 / Annex 3
Overlap / 25°	Test specimen No.	4	5	6
	Number of strikes/dispersi on pattern	3 / Annex 4	3 / Annex 4	3 / Annex 4

Three drop tests each shall be carried out at the above test conditions. In the event of inhomogeneous protective materials, the number of drop tests with the knife (blade) and nail (spike) shall be doubled.

If test specimens consist of several panels that are in contact with each other, the junctures (contact points) shall be tested under the same conditions. In the event of overlapping designs the areas of coverage shall be tested.

The strikes shall be distributed across the surface of the test specimen in accordance with Annex 2 and Annexes 3 and 4, if applicable.

For blade (knife) tests, the blade (lateral axis) shall be positioned in such a way with respect to the test specimen, that the test specimen incurs the maximum effect possible.

For stab testing in accordance with section 7 (injection cannula), the test tool shall be dropped six times onto the test specimen at angles of incidence of 90° and 60° each, with

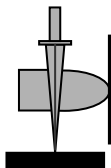

 <p><b>VPAM</b> Association of test laboratories for bullet resistant materials and constructions</p>	<p>Test Standard</p> <p><b>“Stab and Impact Resistance”</b> <b>- Requirements, classifications and</b> <b>test procedures -</b></p>	<p><i>VPAM</i> <i>KDIW 2004</i> <b>Edition: 18.05.2011</b></p>
--	---	--

prior conditioning. Perforation by pushing-through the injection cannula is to be tested three times each at an angle of 90°, with prior conditioning.

**Upper body protection for females** shall be tested twice in the breast area per energy level, in accordance with the required classification, at an angle of incidence of 90°. Testing shall be completed in both the transition area into the breast moulding and the breast tip. Test results shall be determined as per section 10.13.

#### **10.10 Accuracy of Strikes**

The distance between the actual impact point of the test tool and the designated impact point shall not exceed 5 mm in any direction, unless otherwise stated.

#### **10.11 Ambient Temperature**

Testing shall be carried out at an ambient temperature of  $+20 \pm 3$  °C.

#### **10.12 Conduct of Testing**

A previously verified test tool shall be attached to the fixture in accordance with the test requirement (class).

Test specimens conditioned as per section 10.3 shall be placed on the plasticine block for testing. The location of the strikes and the direction (in the event of designs that butt up against one another or overlap) of the test tool shall be selected in such a way that critical areas are tested with sufficient reliability.

In the course of the testing, the drop mass shall be lifted to a height such that the specified impact energy is achieved. Subsequently, the drop mass shall be dropped onto the test specimen.

The push-through test shall be carried out as per section 7.

A **new** test tool shall be used for each single strike or push-through test.

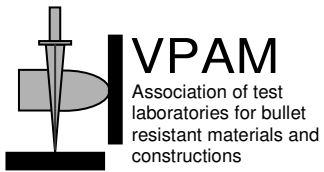
	<p>Test Standard</p> <p><b>“Stab and Impact Resistance”</b>  <b>- Requirements, classifications and test procedures -</b></p>	<p><i>VPAM</i>  <b>KDIW 2004</b>  <b>Edition: 18.05.2011</b></p>
---	---	--

Heated and cooled test specimens shall be tested at the intervals of 2, 5 and 8 minutes (tolerance: + 15 seconds) after removing them from the climatic conditioning cabinet. During the time periods, in which the deformation/penetration depths in the plasticine are determined, the test specimen shall not be removed (establishment of comparable testing conditions). Should further tests be made with the test specimens, they shall be re-conditioned for a minimum of 30 minutes.

If individual components of body armour of a specific class are comparable in terms of material, construction and processing, the test may be conducted on different components (e.g. arm/leg protectors, breast/back protectors).

In the event of groin protectors and elements of body armour, which are too small to meet the requirement for the minimum distance between strikes (as per Annexes 2 through 4), at least one strike shall be delivered on the test specimens conditioned in line with section 10.3. When tests are conducted with blade and spike, the penetration depth shall be determined, and in the event of block tests the average deformation depth shall be established.

If a weak spot is found in the course of testing, it shall be verified using two more strikes. The test tool shall be impacted from the direction at which it is expected to cause the deepest penetration.

### **10.13 Determination of the Test Results**

The result of the test strike shall be evaluated after each single stab or impact (see section 11.1).

The deformation in the plasticine shall be measured after each test strike. If the test specimen is pressed into the plasticine to such an extent that the edge of the sample causes a visible imprint in the plasticine, this additional impression shall not be counted as a part of the deformation depth.

After each individual test strike, the plasticine shall be smoothed out and drawn off with a blade, and the strapped test specimen shall be flattened.

In the event of rigid protective materials, which remain permanently deformed after a strike, it shall be ensured that before the subsequent strike the materials are in complete contact with the plasticine.

### **10.14 Repetition Testing**

Should the results not allow for unequivocal evaluation, the test institute shall repeat the test on analogous locations. These locations shall be unaffected by previous strikes.

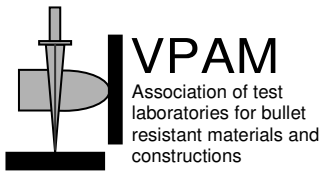
	<p style="text-align: center;">Test Standard</p> <p style="text-align: center;"><b>“Stab and Impact Resistance”</b> - Requirements, classifications and test procedures -</p>	<p style="text-align: center;"><i>VPAM</i> <b>KDIW 2004</b> Edition: 18.05.2011</p>
---	---	---

## 11 Evaluation and Documentation of the Test, Test Certificate

### 11.1 Evaluation of the Test

A test in accordance with this test standard shall be considered to be successful if the requirements as per sections 5, 6, 7 or 8 or any combination thereof, or any combination with a ballistic armour which has already been tested, are fulfilled.

Stab and/or impact testing is not passed if:

- the stabbing tool penetrates deeper into the plasticine than the threshold values defined in Tables 1, 2 or 3, or if the applied pressure falls short of the defined pressure
- the blunt impact tool causes a larger deformation depth in the plasticine than the threshold value defined in Table 4 permits
- portions of the test specimen (e.g. metal or plastic fragments) are found in the plasticine.

### 11.2 Test Report

The test report shall document the testing procedure and the result. It shall contain the following minimum descriptions and statements:

- Name and address of the institute conducting the test
- Name and address of the requester
- Manufacturer and place of manufacture of the test specimen or protective equipment
- Brand name and/or type designation of the test specimen or protective equipment
- Number and date of the test report
- Date of test specimen acceptance
- Date of the test
- Test specimen structure, size and mass per item (as per manufacturer)
- Specification of the material, processing information and batch number
- Description of the test requirements
- Description of the test specifications
- Documentation (photographs and description) of the protection area
- Deviations and limitations as to the test requirements/test specifications
- Statement of measurement inaccuracies (if required) and detected errors
- Measurements, examinations, deduced results, when required, tables, graphics, sketches and/or
- Photographs
- Specification of penetration and/or other damages
- Description of particular observances and comments during testing

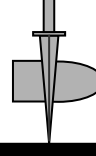
 <p><b>VPAM</b> Association of test laboratories for bullet resistant materials and constructions</p>	<p>Test Standard</p> <p><b>“Stab and Impact Resistance”</b> <b>- Requirements, classifications and test procedures -</b></p>	<p><i>VPAM</i> <i>KDIW 2004</i> <b>Edition: 18.05.2011</b></p>
--	--	--

- Description of test results which exclusively refer to the test specimen
- Description regarding the issued test certificate or verification certificate, as appropriate
- Statement that, without permission of the institute conducting the test, the test report shall not be copied
- Name and signature of the person in charge of the test

### 11.3 Test Certificate/Verification Certificate

In the event of a positive test result, a test certificate shall be issued. Only members of VPAM are entitled to issue a test certificate in accordance with this test standard.

The test certificate shall document the classification according to this test standard and any other requirements beyond the remit of the test standard. In the event that the test is not passed, no test certificate shall be issued. The requester shall, however, receive a test report.

Should the requester require that a test tool be used which is not classified as per Tables 1 through 4 of this standard, in the event of passing the test, a test report and a verification certificate shall be issued.

The test certificate / verification certificate shall clearly indicate that it only applies to the tested specimen. It contains the following minimum descriptions and statements:

- Name and address of the institute conducting the test
- Name and address of the requester
- Manufacturer and place of manufacture of the test specimen or protective equipment
- Object and type designation of the test specimen or protective equipment
- Description of the test requirements
- Classification according to Tables 1, 2, 3 or 4
- Annex for documenting the protection area
- Number and publication date of the test certificate/verification certificate
- Number of the test report
- Date and location of the test
- Statement regarding the validity and distribution of the test certificate/verification certificate

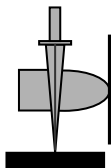
 <p><b>VPAM</b> Association of test laboratories for bullet resistant materials and constructions</p>	<p>Test Standard</p> <p><b>“Stab and Impact Resistance”</b> <b>- Requirements, classifications and test procedures -</b></p>	<p><i>VPAM</i> <i>KDIW 2004</i> <b>Edition: 18.05.2011</b></p>
--	--	--

#### **11.4 Validity of the Test Certificate/Verification Certificate**

The test certificate/verification certificate is only valid if subsequently manufactured protective equipment is identical with the tested sample.

The test certificate/verification certificate shall expire after 5 years or when the manufacturer alters the design of the protective equipment with regard to the tested sample (changing materials or their strengths or processing, etc.)

#### **11.5 Reproducibility of the results**

The requester shall retain the specimens, so that the test results may be reconfirmed, at a later date.

#### **11.6 Specifications of the Materials/Material Processing**

Specifications of the materials and their processing, including in the event of metals the melt analysis in accordance with EN 10204, shall be stored at the institute conducting the test.

## Annex 1: Measuring and Targeting Set-up

Drawing No 4: Drop Test Apparatus

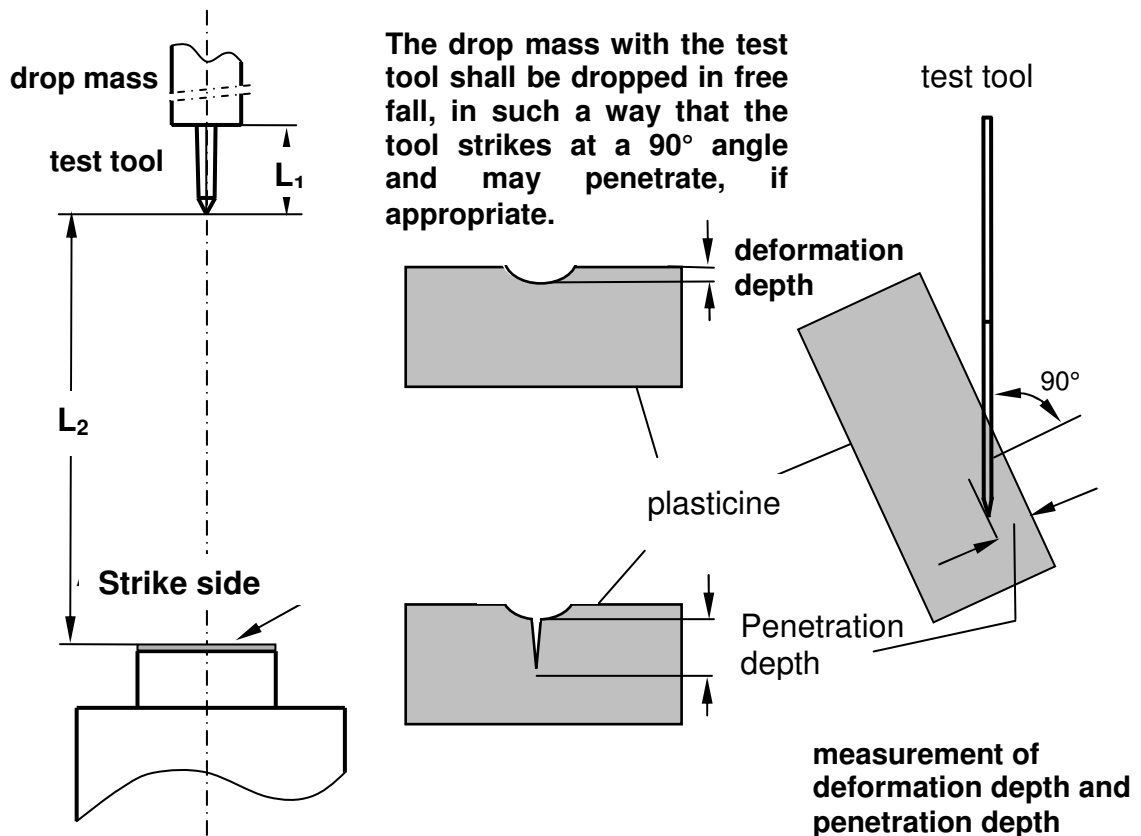

### Stab and Impact Tests

<b>Drop mass:</b> 2.5 kg including test tool	<b>Block (edge of a block)</b>
<b>Strike energy:</b> 15 J: $L_2 = 0.61$ m	$L_1 = 50 \pm 0.5$ mm
25 J: $L_2 = 1.02$ m	
40 J: $L_2 = 1.63$ m	<b>Blade</b>
<b>Drop mass:</b> 5.0 kg including test tool	$L_1 = 80 \pm 0.5$ mm
<b>Strike energy:</b> 65 J: $L_2 = 1.33$ m	<b>Spike</b>
80 J: $L_2 = 1.63$ m	$L_1 = 80 \pm 0.5$ mm
100 J: $L_2 = 2.04$ m	<b>Injection cannula</b>

Tolerances: Drop mass: 0.3 kg including test tool  
 Strike energy 2.5 J:  $L_2 = 0.85$  m  
 $L_1 =$  entire needle length  
 Drop height  $\pm 1$  mm, drop mass  $\pm 10$  g

In order to achieve strike energies of 15, 25 and 40 J, a drop mass of 2.5 kg is required, and for strike energies of 65, 80 and 100 J, a drop mass of 5 kg is required. The institute conducting the test shall ensure that the required strike energy is achieved, if required, by way of measurement.

**Annex 2: Presentation of the Stab Impact Locations**

The materials shall be tested at three different locations on the specimen, at an angle of 90°.

Drawing No 5: Stab Impact Locations

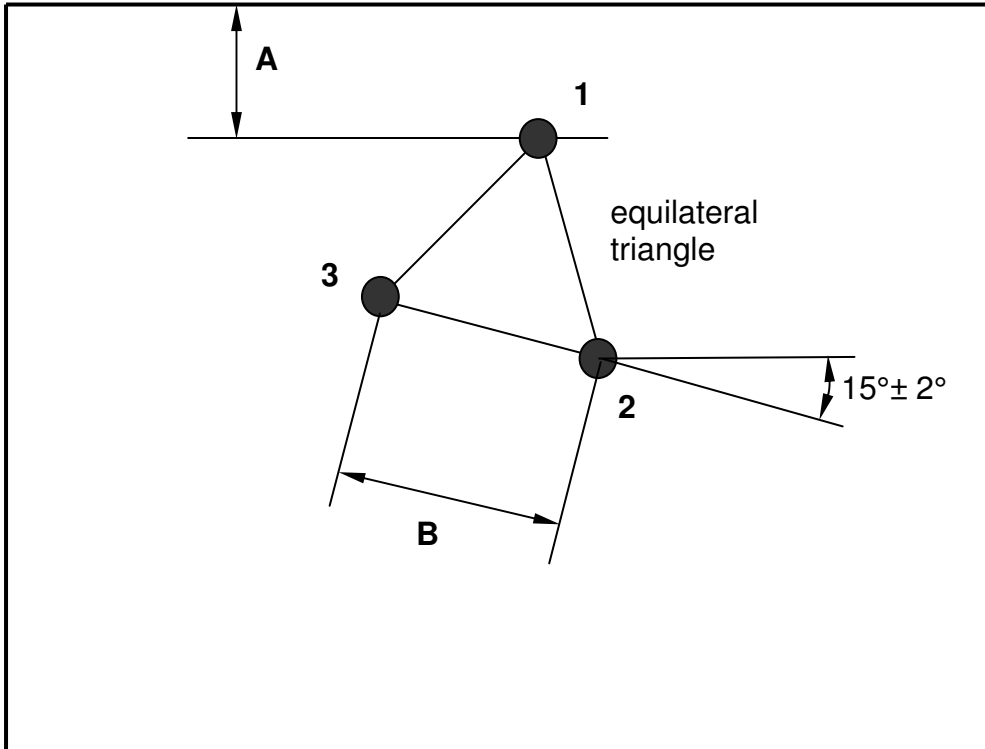

Testing shall be carried out according to the indicated sequence. Strike No 1 shall be placed at the distance of  $50 + 5$  mm ( $A$ ) from the edge of the protection area. The two subsequent strikes shall be placed as per the sketch, at the minimum distance of 80 mm ( $B$ ) from each other and at least 50 mm from the edge of the protection area. All strikes shall be located at a distance greater than 100 mm from the interior edges of the plasticine box.

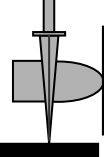
 <p><b>VPAM</b> Association of test laboratories for bullet resistant materials and constructions</p>	<p>Test Standard</p> <p><b>“Stab and Impact Resistance”</b> - Requirements, classifications and test procedures -</p>	<p><i>VPAM</i> <i>KDIW 2004</i> Edition: 18.05.2011</p>
--	---	---

### Annex 3: Presentation of the Stab Impact Locations in the Event of Junctures

In addition, the junctures shall be tested at three different locations at an angle of 90°.

Drawing No 6: Stab Impact Locations in the Event of Junctures

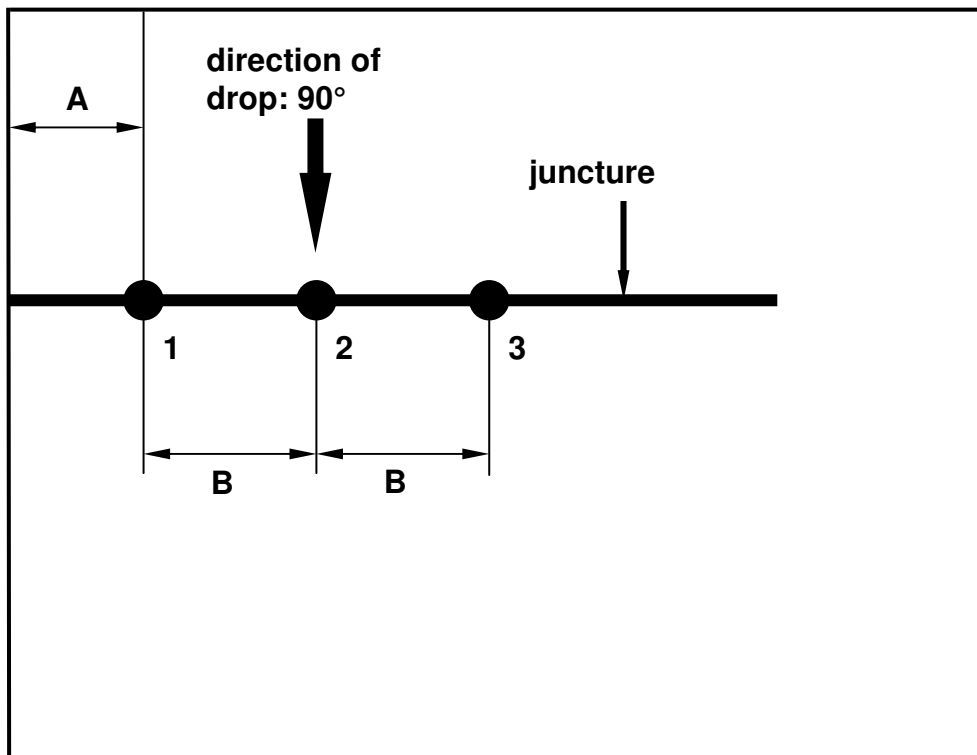

Testing shall be conducted according to the indicated sequence. Strike No 1 shall be placed at the distance of 50 + 5 mm (A) from the edge into the juncture. The two subsequent strikes shall be placed, as per the sketch, at a minimum distance of 80 mm (B).

All strikes shall be located at a distance greater than 100 mm from the interior edges of the plasticine box.



**Annex 4: Presentation of the Stab Impact Locations in the Event of Overlaps**

In addition, overlaps shall be tested at three different locations at an angle of 25°.

Drawing No 7: Stab Impact Locations in the Event of Overlaps

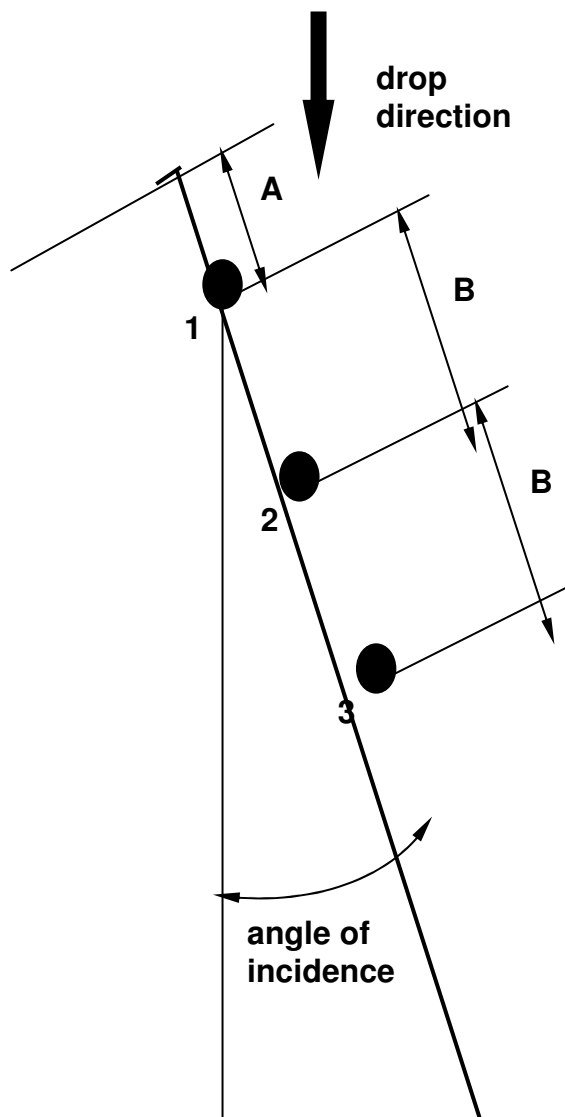

Testing shall be carried out according to the indicated sequence. Strike No 1 shall be placed at a distance of 50 mm + 5 mm (A) from the edge in between the overlapping materials. The two subsequent strikes shall be placed as per the sketch, at a minimum distance of 80 mm (B).

All strikes shall be located at a distance greater than 100 mm from the interior edges of the plasticine box.

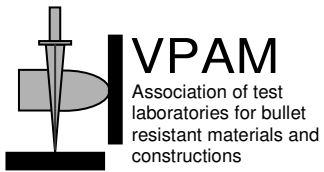
	<p>Test Standard</p> <p><b>“Stab and Impact Resistance”</b>  <b>- Requirements, classifications and test procedures -</b></p>	<p><i>VPAM</i>  <b>KDIW 2004</b>  <b>Edition: 18.05.2011</b></p>
---	---	--

## Annex 5: Testing of Protective Helmets

Helmet shell, visor, neck protection and chin guard shall all be tested for stab resistance. To do so, a drop test apparatus in accordance with DIN EN 13087 shall be used. The drop mass with the retaining clamp shall correspond to ECE 22.

Testing shall be conducted with the spike as described in section 6.

The strike energy levels for testing the

- helmet shell
- the visor
- the neck protection
- the chin guard

shall be determined by the requester/procurer.

Table 6: Number of Strikes

Test specimen / angle of incidence		Test conditions		
		+20° C	+70° C	-20° C
Helmet shell / 90°	Test specimen No.	1	2	3
	Number of strikes	5	5	5
Visor / 90°	Test specimen No.	1	2	3
	Number of strikes	3	3	3
Neck protector/ 90°	Test specimen No.	1	2	3
	Number of strikes	3	3	3
Chin guard/ 90°	Test specimen No.	1	2	3
	Number of strikes	3	3	3

The **helmet shell** shall be tested from above (impact point within a circle of 100 mm diameter around the top of the helmet shell), from the front, the back, and both sides. The test impacts shall be located at a minimum distance of 15 mm from the edge. When testing from above, the force transmitted by the drop mass with the retaining clamp on the force measurement device, shall be measured. The test set-up for tests from the ahead, the back and the two sides is shown in Drawing No 8.

The **visor** shall be tested whilst fixed onto the helmet, at various locations (distance from the upper edge of the visor 50 mm, 100 mm and 150 mm) along the centre axis. In so doing, the extent of the visor deviation (/sag) shall be recorded (see Drawing No 8).

The testing of the **neck protector** shall be conducted on different locations of the surface (minimum distance of 15 mm from the edge). In so doing, the neck protector shall be removed from the helmet and be placed on plasticine.

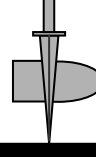
 <p><b>VPAM</b> Association of test laboratories for bullet resistant materials and constructions</p>	<p>Test Standard</p> <p><b>“Stab and Impact Resistance”</b> - Requirements, classifications and test procedures -</p>	<p><i>VPAM</i> <i>KDIW 2004</i> Edition: 18.05.2011</p>
--	---	---

The **chin guard** shall be tested whilst fixed onto the helmet, at different locations in the median area (minimum distance of 15 mm from the edge and another impact).

When testing:

- the **helmet shell** and the visor, neither the tip of the test tool nor parts of the visor shall touch the surface of the drop mass with the retaining clamp, as per ECE R 22.
- the **neck protector**, the tip of the drop mass shall project no more than 5 mm through the neck protector. The sum of the penetration depth and the deformation depth in the plasticine shall not exceed 20 mm.
- the **chin guard**, neither the tip of the drop mass nor parts of the chin guard shall touch the surface of the drop mass with the retaining clamp, as per ECE R 22.

Drawing No 8: Apparatus for testing the helmet from ahead, the rear surface and from both sides

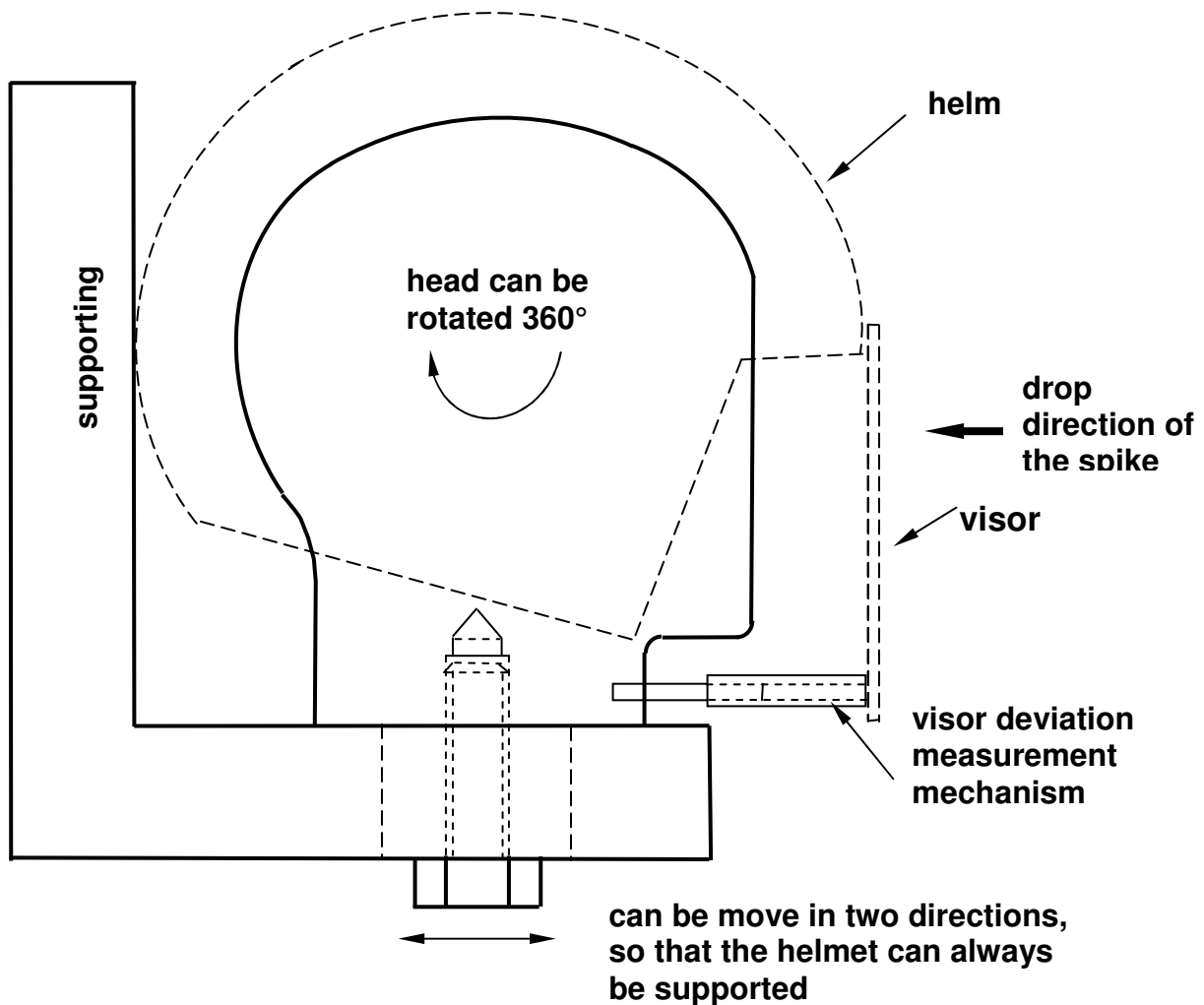

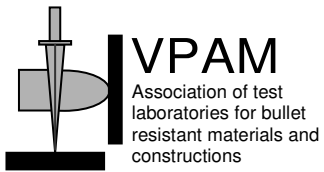
	<b>Test Standard</b> <b>“Stab and Impact Resistance”</b> <b>- Requirements, classifications and test procedures -</b>	<b>VPAM</b> <b>KDIW 2004</b> <b>Edition: 18.05.2011</b>
---	---	---

## Annex 6: Testing of Protective Shields

The protective shield shall be tested for its stab and impact resistance. To do so, a drop test apparatus shall be used.

Testing shall be conducted with the blade, as described in section 5, the spike, as described in section 6, and the block, as described in section 8.

The strike energy levels for testing the forearm rest and the shield surface (outside the forearm rest area) shall be determined by the requester/procurer.

Table 7: Number of strikes per Test Tool

Impact point / angle of incidence		Test conditions		
		+20° C	+70° C	-20° C
	Test specimen No.	1	2	3
Forearm rest / 90°	Number of strikes	3	3	3
Shield surface/ 90°	Number of strikes	3	3	3

For testing, the protective shield shall rest on the tube between the handle and the bracket (arm strap), with the tube resting along its entire length on a rigid surface, a board (spacer), as required, in order to preclude effects of the handle and the bracket. In addition, the shield shall be supported on the edges in such a way that it rests horizontally and firmly (see Drawing 9).

For every drop test a new tube section shall be used.

In the area of the carrying system (forearm rest, protected area at least 150 x 500 mm) the strikes shall be located at the minimum distance of 10 mm from the edge of the forearm rest and at least 60 mm from each other. At least one strike shall be delivered into the centre line of the arm rest.

Outside the forearm rest (shield surface) the test shall be conducted with low strike energy levels (minimum distance of 60 mm from the support points of the forearm rest and from each other).

During testing:

- there shall be, under no circumstances, any penetration of the material in the arm area,
- in addition, the shield shall not be penetrated by more than 20 mm in other areas and shall have a deformation < 20 mm (with respect to the original surface).

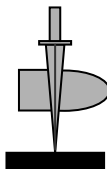
 <p><b>VPAM</b> Association of test laboratories for bullet resistant materials and constructions</p>	<p>Test Standard</p> <p><b>“Stab and Impact Resistance”</b> <b>- Requirements, classifications and test procedures -</b></p>	<p><i>VPAM</i> <i>KDIW 2004</i> Edition: 18.05.2011</p>
--	--	---

Drawing No 9: Protective Shield Support

